

## RGB Intelligent economical color mark sensor GCS111 manual

Thank you for purchasing Garantta products.  
Please read this instruction manual carefully and completely to use this product correctly and reasonably. Please keep this instruction manual in a handy place for quick reference.

### Warning

- Do not use this product as a detection device for human protection.
- If the purpose is human protection, please use products that are applicable to human protection in various countries such as OSHA, ANSI and IEC.

### Specifications

Type	Cable type	
Detection distance	10±3.5mm	
Spot size	1x5mm(Set distance:10 mm)	
Supply voltage	12~24VDC±10%/pulsation P-P 10% or less	
Power consumption	Power 850mW or less (power supply voltage 24V, current consumption 30mA or less)	
Cut-in mode	<NPN output type> Mark mode Low (ON):0 to 2V DC Source current 0.5mA or less Input impedance 10KΩ approx Color mode High (OFF): 5V to +V DC, or open	<PNP output type> Color mode High(ON):5V to +V DC Sink current 3mA or less Input impedance 10KΩ approx Mark mode Low (OFF): 0 to 0.6V DC, or open
	<NPN output type> NPN open collector transistor • Maximum inflow current: 50mA • Applied voltage: 30V DC or less (between output and 0V) • Residual voltage: 1.5V or less (when the current flowing in is 50mA) (Note 1)	<PNP output type> NPN open collector transistor • Maximum source current: 50mA • Applied voltage: 30V DC or less (between output and +V) • Residual voltage: 1.5V or less (when the outflow current is 50mA) (Note 1)
Output action	Color mark mode: ON when light enters, Color mode: ON when consistent	
Short circuit protection	Equipped (automatic reset type)	
Reaction time	Color mark mode: 45μs or less, color mode: 150μs or less	
Working status indicator light	Orange LED (lights up when output is ON)	
Ambient temperature	10~+55°C (note no condensation or freezing) during storage: -20~+70°C	
Ambient humidity	35~85%RH, storage: 35~85%RH	
Light emitting components	Red/green/blue composite LED (projection peak wavelength: 640nm/525nm/470nm)	
Protective structure	IP 67 (IEC)	
Model	NPN NO GCS111	
	PNP NO GCS111-P	

(Note 1): When not specified, the measurement conditions are operating ambient temperature = +23°C

### Precautions

- This product is developed and manufactured for use in industrial environments.
- Please make sure that the power is turned off when wiring.
- Note that incorrect wiring may damage the sensor.
- Please make sure that the power supply voltage varies within the rated range.
- Do not apply a voltage exceeding the rated range or connect directly to the AC power supply, as this may damage or burn the sensor.
- If noise-generating equipment such as a switching regulator or conversion motor is used near this product, please ground the equipment frame ground terminal (F.G).
- If the power is provided by a commercial switching regulator, make sure that the power frame ground terminal (F.G) is grounded.
- Do not use within a short period of 0.5s after the power is turned on.
- Short circuit of the load or incorrect wiring connection may cause damage or burning of the machine, please pay attention.
- Do not run the line together with high-voltage lines or power lines or in the same wire pipe, as this may cause malfunction due to induction.
- Do not expose the sensor directly to the light of quick-start lamps or high-frequency lighting equipment or sunlight, etc., as this will affect the detection performance.
- Do not touch the sensor lens directly with your hands.  
If the lens is dirty, wipe it gently with a soft cloth.
- When the inside of the lens is not clear, please remove the lens and clean it.
- For cables with connector type GCS111, be sure to use the separately sold cable with connector.
- The total length of the extension cable (0.3mm<sup>2</sup> or more) does not exceed 100m.  
To reduce noise, make the wiring as short as possible.
- This sensor is only suitable for indoor use.
- Avoid dust, dirt, water vapor or corrosive gas.
- Do not directly contact the sensor with water, oil, grease or organic solvents such as thinners.
- Do not bend the root of the cable or apply pressure, such as tension of more than 76N.
- This sensor cannot be used in an environment with flammable and explosive gases.
- The sensor cannot be disassembled or modified.

### Install

- Please pay attention to the installation direction of the sensor.

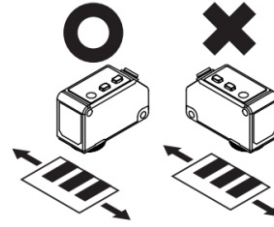

The detection method in the direction shown in the figure will make the action unstable, so try to avoid it.

- The tightening torque should be below 0.8N.m.

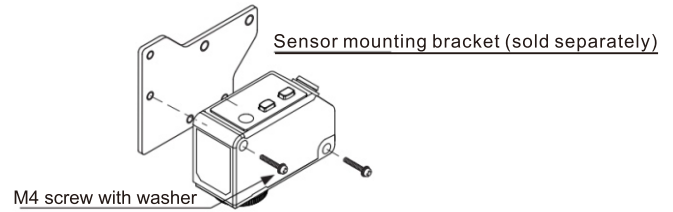

### Part Name

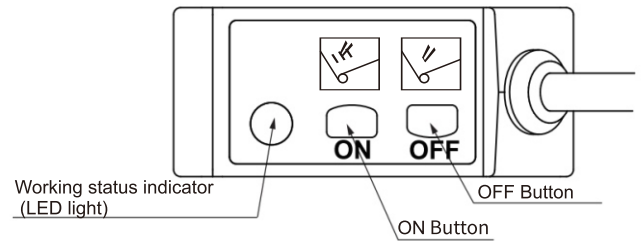

### I/O Circuit Diagram

- NPN Out put type

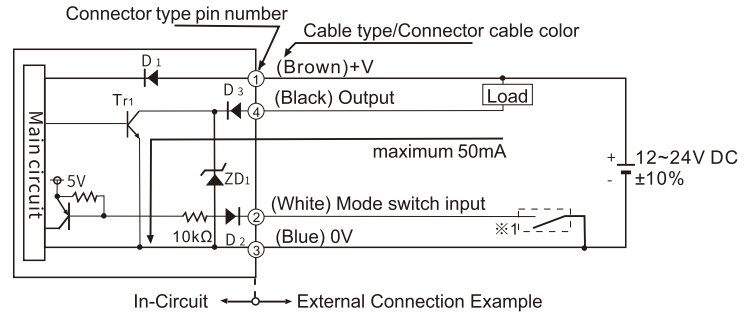

- PNP Out put type

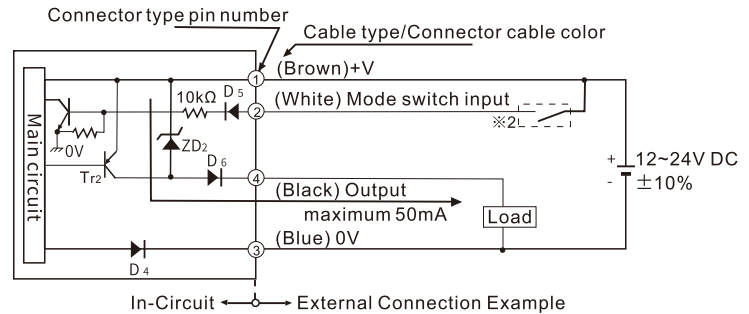

※1

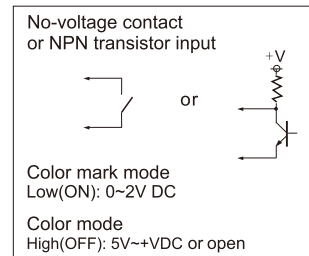

※2

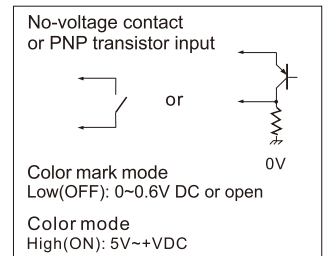

Symbols. ...D<sub>1</sub>,D<sub>2</sub>,D<sub>3</sub>,D<sub>4</sub>,D<sub>5</sub>,D<sub>6</sub>: Reverse power polarity protection diodes  
Z<sub>D1</sub>,Z<sub>D2</sub>: Current absorbing Zener diode  
T<sub>r1</sub>: NPN Output transistor  
T<sub>r2</sub>: PNP Output transistor

- Connector pin locations for connector type GCS111

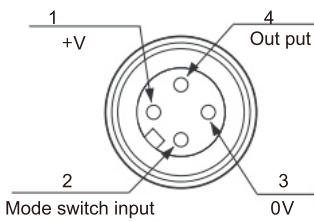

### Teaching Methods

Before setting the teaching mode, be sure to confirm the setting of the color mark mode or color mode.

#### 2-point teaching in color mark mode

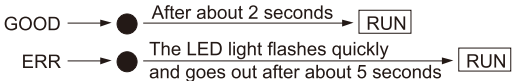
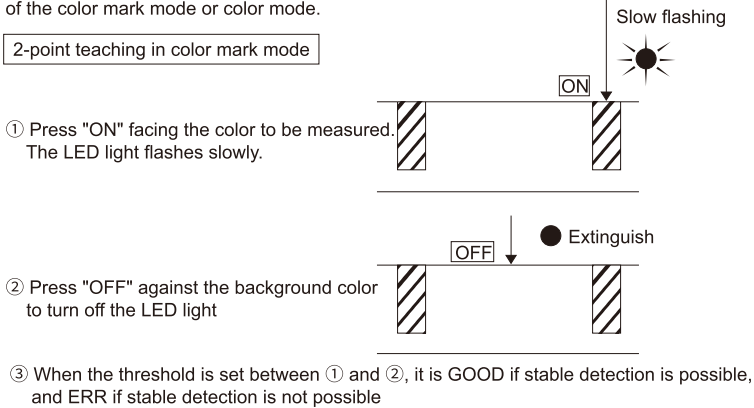

(Note: When ERR occurs, please perform the teaching operation again. If you do not re-teach, the result of the last teaching will be used to run)

#### One-point instruction on color mode

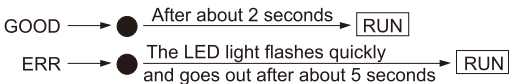
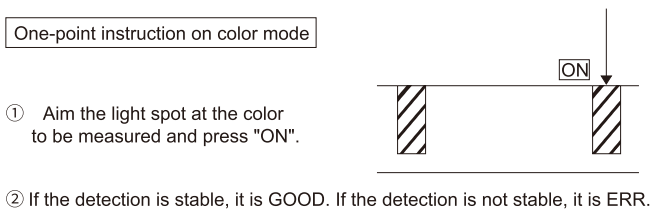

(Note): When ERR occurs, please perform the teaching operation again. If you do not re-teach, the result of the last teaching will be used to run)

### Color mark mode sensitivity adjustment

When the detection is unstable, the sensitivity adjustment function can change the product's internal judgment of the amount of light entering (i.e. threshold adjustment).

- Several states of the sensitivity adjustment function

State	Numeric	LED (Number of flashes X)
1	$C = C - D * 80\%$	1
2	$C = C - D * 60\%$	2
3	$C = C - D * 40\%$	3
4	$C = C - D * 20\%$	4
5 (Note 1)	$C = C$	5
6	$C = C + D * 20\%$	6
7	$C = C + D * 40\%$	7
8	$C = C + D * 60\%$	8
9	$C = C + D * 80\%$	9

Note 1: The factory setting status of the product is the status of the GCS111 product after teaching.  
Note 2: C value is the threshold value; D value is the calculated value of the light entering the color mark (A) and the background mark (B).

- Sensitivity adjustment function diagram

After entering the sensitivity adjustment function, if no operation is performed, the LED will turn off for 0.5S and then flash (X) times. The number of flashes indicates the current status of the product.

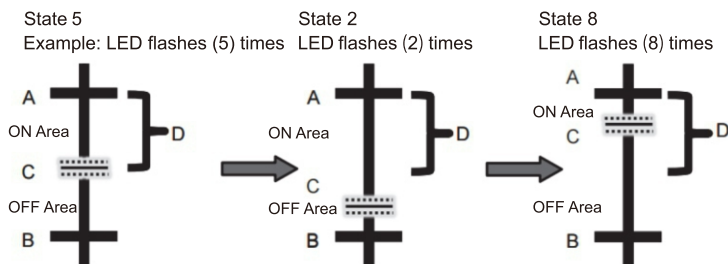

A, B, C, D is the amount of light entering.

Note: A value is the amount of light entering the color code  
B value is the amount of light entering the background

- How to enter and operate the sensitivity adjustment function

- In normal operation, for easy observation, please press the OFF key once when the LED is off, and then press and hold the ON key. After about 6 seconds, the LED light will turn on. Release the ON key to enter the sensitivity adjustment function.
- After entering the sensitivity adjustment function, press the ON key (+) and OFF key (-) to adjust the sensitivity state.
- After the adjustment, no further guidance is required and the test can be started directly.

- Sensitivity adjustment function operation and LED indication

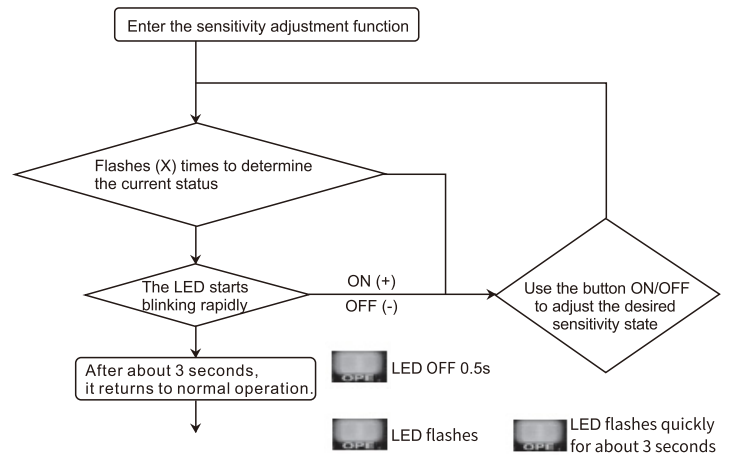

### About error message tips

- When an error message appears, handle it as follows.

Working status indicator (LED light)	Error message content	Deal with
The LED light keeps flashing rapidly and will not turn off automatically.	The load is short-circuited and overcurrent flows.	After turning off the power, check the load.

### Dimensions (Unit:mm)

- Cable Type /GCS111

- CableType/GCS111-P

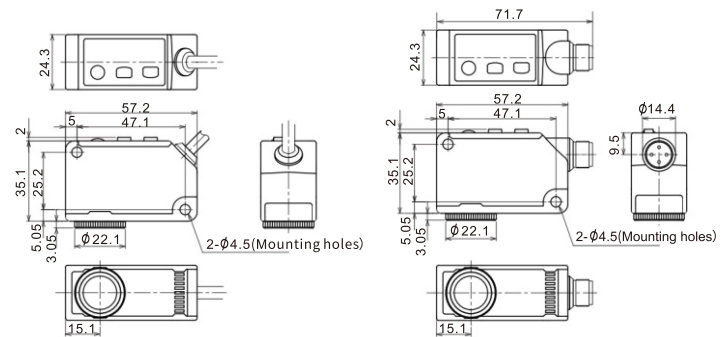

### Name and content of toxic and hazardous substances or elements in products (Requirements for pollution control of electronic information products)

Part Name	Toxic and hazardous substances or elements					
	lead (Pb)	Cadmium (Cd)	Hexavalent chromium (Cr6+)	Mercury (Hg)	Polybrominated biphenyls (PBB)	Polybrominated diphenyl ethers (PBDE)
Mounting circuit board	×	○	○	○	○	○
Exterior parts (※)	×	○	○	○	○	○
Other	○	○	○	○	○	○

○: It means that the content of the toxic and hazardous substance in all homogeneous materials of the component is below the limit requirements specified in the standard "Limit Requirements for Toxic and Hazardous Substances in Electronic Information Products".  
×: It means that the content of the toxic and hazardous substance in at least one homogeneous material of the component exceeds the limit requirements specified in the "Limit Requirements for Toxic and Hazardous Substances in Electronic Information Products" standard.

※: Exterior parts include outer shell, nameplates, optical parts, cables, connectors, wiring screws, terminals, mounting brackets and other parts.



### Batch Description

25N01  
└── Batch  
└── Years

### Technical consultation

Garantta Sensor Technology (Shenzhen) Co., Ltd.  
Guangdong Garantta Sensor Technology Co., Ltd.  
Address: Longhua District, Shenzhen, China  
Hotline/Fax: (86) 0755-2317-1049  
Web: <http://www.garantta.com>  
E-mail: [info@garantta.com](mailto:info@garantta.com)